

REV.	DESCRIPTION	DATE BY
-	FIRSTRELEASE	12/10/07 JJR

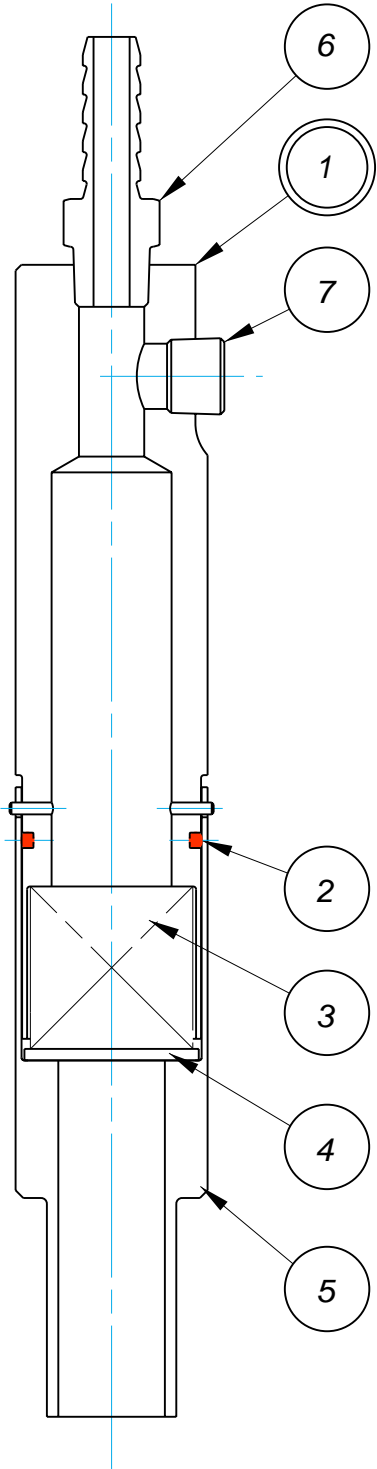

7	2007-2A-0185	-	PIPEPLUG, 1/8 N.P.T., SOCK. HD., S.S.	1	EA.
6	2007-2A-0019	-	HOSEBARBFITTING, 1/4" X 1/8N.P.T.	1	EA.
5	3026-GC-0108	A	TIP, 7.0 CC.	1	EA.
4	3026-GC-0607-40	-	FILTER, 316LS.S. x 40 MICRON	1	EA.
3	0012-2A-0037	-	COMPRESSION SPRING, S.S., 1"LG.	1	EA.
2	0016-2A-5061	-	O-RING, SILICONE, SIZE -018	1	EA.
1	3026-GC-0605	-	BARREL ASS'Y, LONG (MODIFIED)	1	EA.

ITEM	PART NO.	REV	DESCRIPTION	QTY	UOM
------	----------	-----	-------------	-----	-----

KINEMATICS & CONTROLS CORPORATION

TOLERANCES (EXCEPT AS NOTED)	TITLE FILLING GUN... 7.0 cc. (w/316 WOVEN S.S. FILTER)	JOB NO. 3026
.XXX±.005 .XX±.010	MAT'L SEE TABLE	FINAL ASS'Y 3026-0601
FRACT.±.015 ANG.±1/2°	FINISH N/A	REQ'D N/A
DWN JJR	DATE 12/10/07	SCALE NONE
APP'D -	DATE -	DWG. NO. 3026-GC-0601
		REV. -

NOTICE!

This drawing, including all information contained hereon, is the exclusive proprietary property of Kinematics & Controls Corporation. It is disclosed with the understanding it will be retained in confidence, and will neither be duplicated or copied in whole or in part, nor used for any purpose other than that for which disclosed. This drawing is to be returned upon request.