

1

2

PRINTED:  
12/14/2017STATUS:  
Released

DWG. NO.

3002-SE-0094

SH. 1

REV. C

## REVISIONS

REV.	DESCRIPTION	DATE BY	DATE APP'D
C	REDESIGNED TIP ASSEMBLY; 3002-0093-20 WAS 3002-0093-15/40.	3/29/17 CIW	4/3/17 JJR

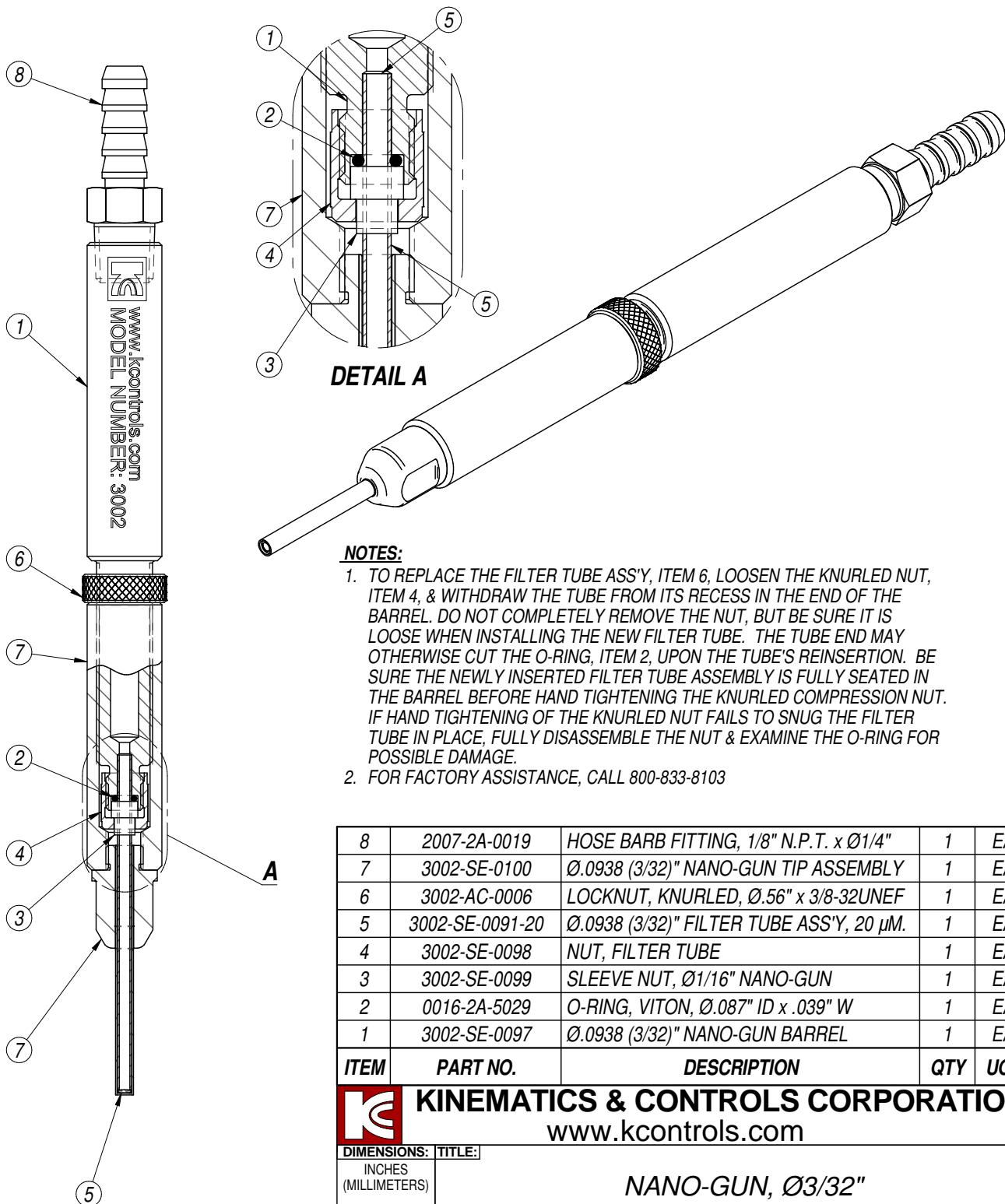

## NOTES:

- TO REPLACE THE FILTER TUBE ASS'Y, ITEM 6, LOOSEN THE KNURLED NUT, ITEM 4, & WITHDRAW THE TUBE FROM ITS RECESS IN THE END OF THE BARREL. DO NOT COMPLETELY REMOVE THE NUT, BUT BE SURE IT IS LOOSE WHEN INSTALLING THE NEW FILTER TUBE. THE TUBE END MAY OTHERWISE CUT THE O-RING, ITEM 2, UPON THE TUBE'S REINSERTION. BE SURE THE NEWLY INSERTED FILTER TUBE ASSEMBLY IS FULLY SEATED IN THE BARREL BEFORE HAND TIGHTENING THE KNURLED COMPRESSION NUT. IF HAND TIGHTENING OF THE KNURLED NUT FAILS TO SNUG THE FILTER TUBE IN PLACE, FULLY DISASSEMBLE THE NUT & EXAMINE THE O-RING FOR POSSIBLE DAMAGE.
- FOR FACTORY ASSISTANCE, CALL 800-833-8103

8	2007-2A-0019	HOSE BARB FITTING, 1/8" N.P.T. x Ø1/4"	1	EA.
7	3002-SE-0100	Ø.0938 (3/32)" NANO-GUN TIP ASSEMBLY	1	EA.
6	3002-AC-0006	LOCKNUT, KNURLED, Ø.56" x 3/8-32UNEF	1	EA.
5	3002-SE-0091-20	Ø.0938 (3/32)" FILTER TUBE ASS'Y, 20 µM.	1	EA.
4	3002-SE-0098	NUT, FILTER TUBE	1	EA.
3	3002-SE-0099	SLEEVE NUT, Ø1/16" NANO-GUN	1	EA.
2	0016-2A-5029	O-RING, VITON, Ø.087" ID x .039" W	1	EA.
1	3002-SE-0097	Ø.0938 (3/32)" NANO-GUN BARREL	1	EA.

ITEM	PART NO.	DESCRIPTION	QTY	UOM
------	----------	-------------	-----	-----



**KINEMATICS & CONTROLS CORPORATION**  
www.kcontrols.com

DIMENSIONS: TITLE:

INCHES  
(MILLIMETERS)

NANO-GUN, Ø3/32"

TOLERANCES: MATERIAL:

(EXCEPT AS NOTED)  
.XXX±.005  
.XX±.010  
FRACT.±1/64  
ANGLE±1/2°

SEE TABLE

FINAL ASSY

3002-0094

SCALE:

FINISH:

REQ'D.

NEXT ASSY

NONE

N/A

1

3002-0094

DRAWN:

DATE:

DWG. NO.:

REV.:

CIW

2/2/01

**3002-SE-0094****C**

## NOTICE!

This drawing, including all information contained hereon, is the exclusive proprietary property of Kinematics & Controls Corporation. It is disclosed with the understanding it will be retained in confidence, and will neither be duplicated nor copied in whole or in part, nor used for any purpose other than that for which disclosed. This drawing is to be returned upon request.

1

2

3

4

SHEET 1 OF 1