

1

2

PRINTED: 12/14/2017	STATUS: Released	DWG. NO. 3002-SE-0062	SH. 1	REV. -
REVISIONS				
REV.	DESCRIPTION	DATE BY	DATE APP'D	
-	INITIAL RELEASE.	3/23/17 CIW	4/3/17 JJR	

D

D

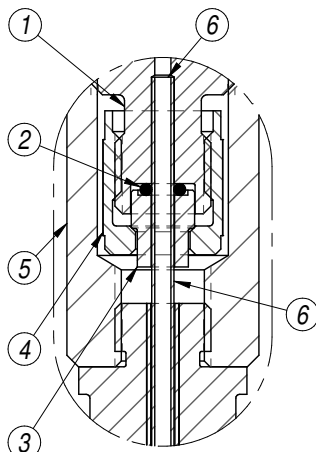
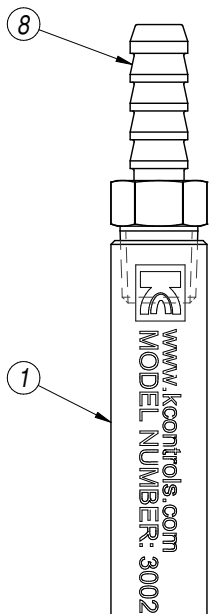

DETAIL A

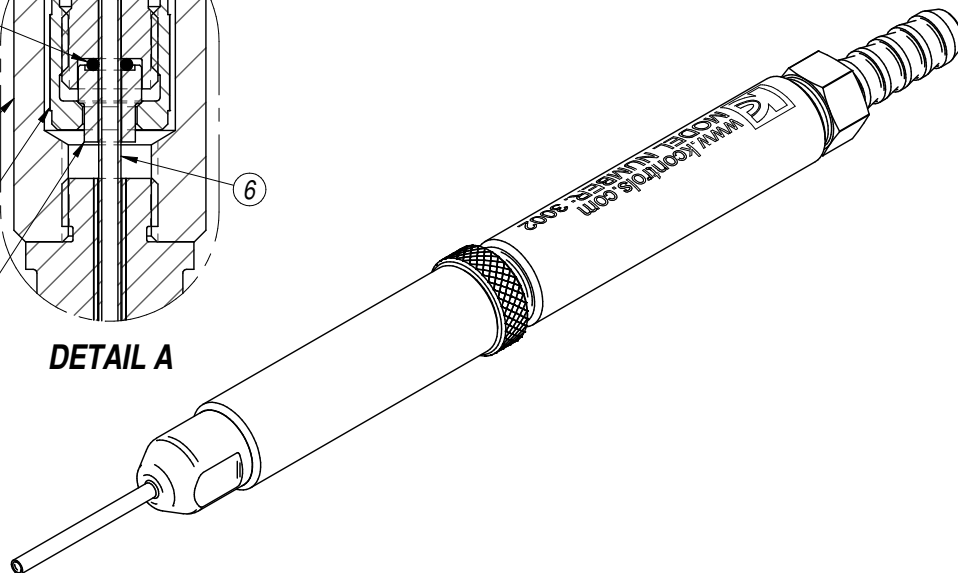

C

C

NOTES:

1. TO REPLACE THE FILTER TUBE ASS'Y, ITEM 6, LOOSEN THE KNURLED NUT, ITEM 4, & WITHDRAW THE TUBE FROM ITS RECESS IN THE END OF THE BARREL. DO NOT COMPLETELY REMOVE THE NUT, BUT BE SURE IT IS LOOSE WHEN INSTALLING THE NEW FILTER TUBE. THE TUBE END MAY OTHERWISE CUT THE O-RING, ITEM 2, UPON THE TUBE'S REINSERTION. BE SURE THE NEWLY INSERTED FILTER TUBE ASSEMBLY IS FULLY SEATED IN THE BARREL BEFORE HAND TIGHTENING THE KNURLED COMPRESSION NUT. IF HAND TIGHTENING OF THE KNURLED NUT FAILS TO SNUG THE FILTER TUBE IN PLACE, FULLY DISASSEMBLE THE NUT & EXAMINE THE O-RING FOR POSSIBLE DAMAGE.
2. FOR FACTORY ASSISTANCE, CALL 800-833-8103

B

B

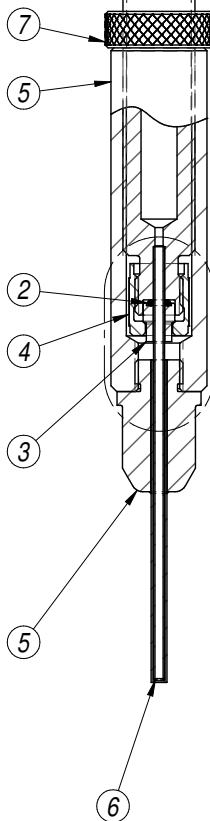

A

8	2007-2A-0019	HOSE BARB FITTING, 1/8" N.P.T. x Ø1/4"	1	EA.
7	3002-AC-0006	LOCKNUT, KNURLED, Ø.56"x3/8-32x.19"	1	EA.
6	3002-SE-0061-20	FILTER TUBE ASSEMBLY, Ø1/16" I.D.	1	EA.
5	3002-SE-0071	Ø1/16" NANO-GUN TIP ASSEMBLY	1	EA.
4	3002-SE-0098	NUT, FILTER TUBE	1	EA.
3	3002-SE-0065	COMPRESS. SLEEVE, Ø1/16" NANO GUN	1	EA.
2	0016-2A-5090	O-RING, BUNA-N, Ø.057" I.D. x .030" W.	1	EA.
1	3002-SE-0064	BARREL, Ø1/16" NANO-GUN	1	EA.

ITEM	PART NO.	DESCRIPTION	QTY	UOM
------	----------	-------------	-----	-----

KINEMATICS & CONTROLS CORPORATION
www.kcontrols.com

DIMENSIONS:	TITLE:	NANO-GUN, Ø1/16" I.D.		
INCHES (MILLIMETERS)				

TOLERANCES:	MATERIAL:	SEE TABLE		
(EXCEPT AS NOTED)				

.XXX±.005	SCALE:	FINISH:	REQ'D.	NEXT ASS'Y
.XX±.010			1	3002-0062
FRACT.±1/64	NONE	N/A		
ANGLE±1/2°				

DRAWN:	DATE:	DWG. NO.:	REV.:
CIW	3/23/17	3002-SE-0062	-

⊕ NOTICE!
This drawing, including all information contained hereon, is the exclusive proprietary property of Kinematics & Controls Corporation. It is disclosed with the understanding it will be retained in confidence, and will neither be duplicated nor copied in whole or in part, nor used for any purpose other than that for which disclosed. This drawing is to be returned upon request.

1

2

3

4