

1

2

3

D

C

B

A

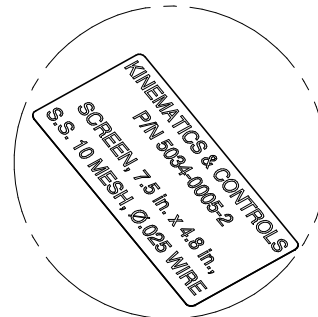
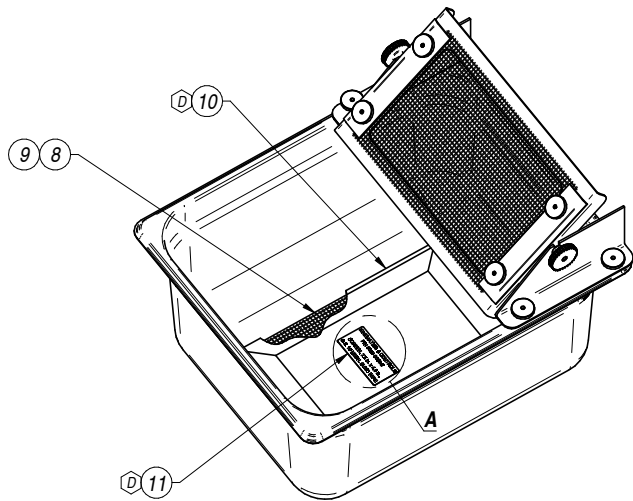
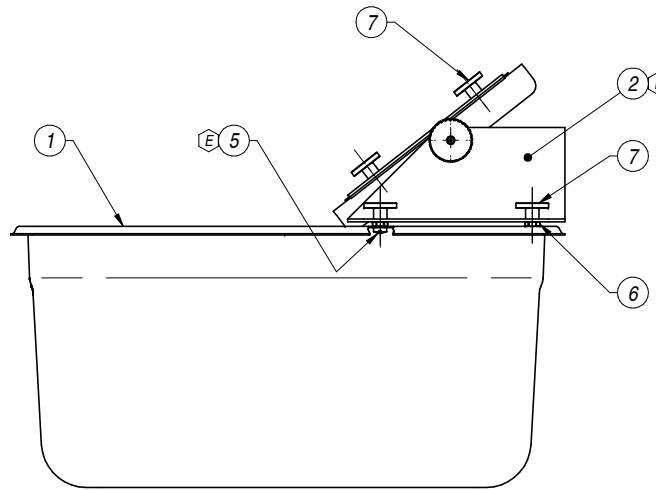
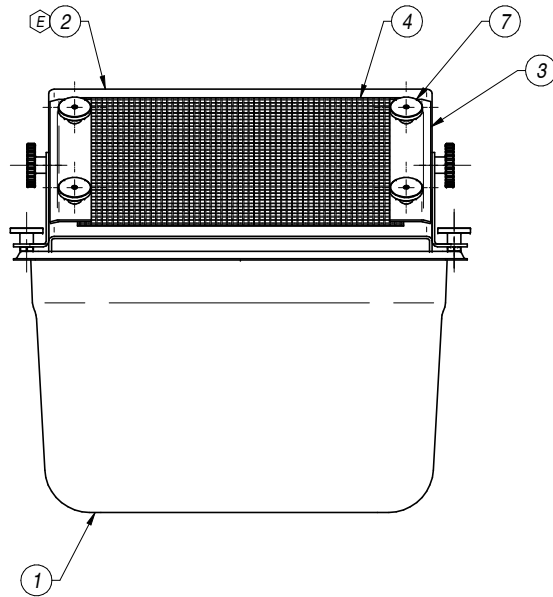

DETAIL A

(LABEL DEPICTED FOR ITEM 8; CREATE SIMILAR LABEL FOR ITEM 9)

⊕ NOTICE!
 This drawing, including all information contained hereon, is the exclusive proprietary property of Kinematics & Controls Corporation. It is disclosed with the understanding it will be retained in confidence, and will neither be duplicated nor copied in whole or in part, nor used for any purpose other than that for which disclosed. This drawing is to be returned upon request.

PRINTED: 12/13/2017 STATUS: Released DWG. NO. 5034-SE-0002 SH. 1 REV. E

REVISIONS				
REV.	DESCRIPTION	DATE BY	DATE APP'D	
B	REDRAWN ON AUTOCAD.	10/14/03 RAC	10/14/03 JJR	
C	ITEM 4 WAS 5034-AC-0005 (A). ADDED ITEMS 10 & 11.	10/14/03 RAC	10/14/03 JJR	
D	ADDED ITEM 12, 5034-0010 PACKAGING ASS'Y; REMOVED 2 ITEMS, 0020-2A-0043 BUBBLE WRAP & 0020-2A-0042 CARTON, CORRUGATED; ADDED ITEMS 10 & 11.	4/22/14 CIW	4/23/14 JJR	
E	REDRAWN ON SOLID EDGE; OBSOLETE ON AUTOCAD: 5034-SE-0003 SCREEN HOLDER ADJUSTABLE ASSY WAS 5034-AC-0003 SCREEN HOLDER; 0028-0001 8-32 x 1/2" SCREW, QTY 4 WAS QTY. 8.	3/31/15 CIW	4/16/15 JJR	

⊕ 12	5034-0010	PACKAGING ASS'Y (NOT SHOWN)	1	EA.
⊕ 11	DYMO 30336	LABEL (PRINTED WITH KCC P/N & DESC.)	1	EA.
⊕ 10	0020-2A-0080	KRAFT PAPER, 7.5" x 15" SHEET	1	EA.
9	5034-SE-0005-03	SCREEN 7.5" x 4.8", 304 S.S., 12 MESH	1	EA.
8	5034-SE-0005-02	SCREEN 7.5" x 4.8", 304 S.S., 10 MESH	1	EA.
7	0018-2A-0001	KNURLED THUMB NUT	8	EA.
6	0038-2A-0001	HEX NUT, 8-32 UNC, STAINLESS	4	EA.
5	0028-2A-0001	M. S., FILLISTER HEAD, 8-32UNC x 1/2" LG.	4	EA.
4	5034-SE-0005-01	SCREEN 7.5" x 4.8", 304 S.S., 8 MESH	1	EA.
3	5034-SE-0004	CLAMPING BAR	2	EA.
2	5034-SE-0003	SCREEN HOLDER, ADJUSTABLE ASSY	1	EA.
1	5034-SE-0001	PAN, LARGE PRODUCT TROUGH ASS'Y	1	EA.

ITEM	PART NO.	DESCRIPTION	QTY	UOM
------	----------	-------------	-----	-----

KINEMATICS & CONTROLS CORPORATION
 www.kcontrols.com

TITLE: LARGE PRODUCT TROUGH ASS'Y
 (9.34 LITER CAP.)

TOLERANCES (EXCEPT AS NOTED) MATERIAL: SEE TABLE FINAL ASSY 5034-0002

SCALE: NONE FINISH: N/A REQ'D. 1 NEXT ASSY 5034-0002

DRAWN: RAC DATE: 10/14/03 DWG. NO. 5034-SE-0002 REV. E

1

2

3

4