

1

2

| REVISIONS | | | |
|-----------|---|----------------|----------------|
| REV. | DESCRIPTION | DATE BY | DATE APP'D |
| A | IN BOM, 3008-AC-1012 (A) WAS (-) | 2/13/08 JJR | 2/13/08 JJR |
| A1 | REDRAWN ON SOLID EDGE; OBSOLETE ON GENERIC CADD; NO CHANGE IN FORM, FIT, OR FUNCTION. | 8/5/13 CIW | 9/19/13 JJR |

D

D

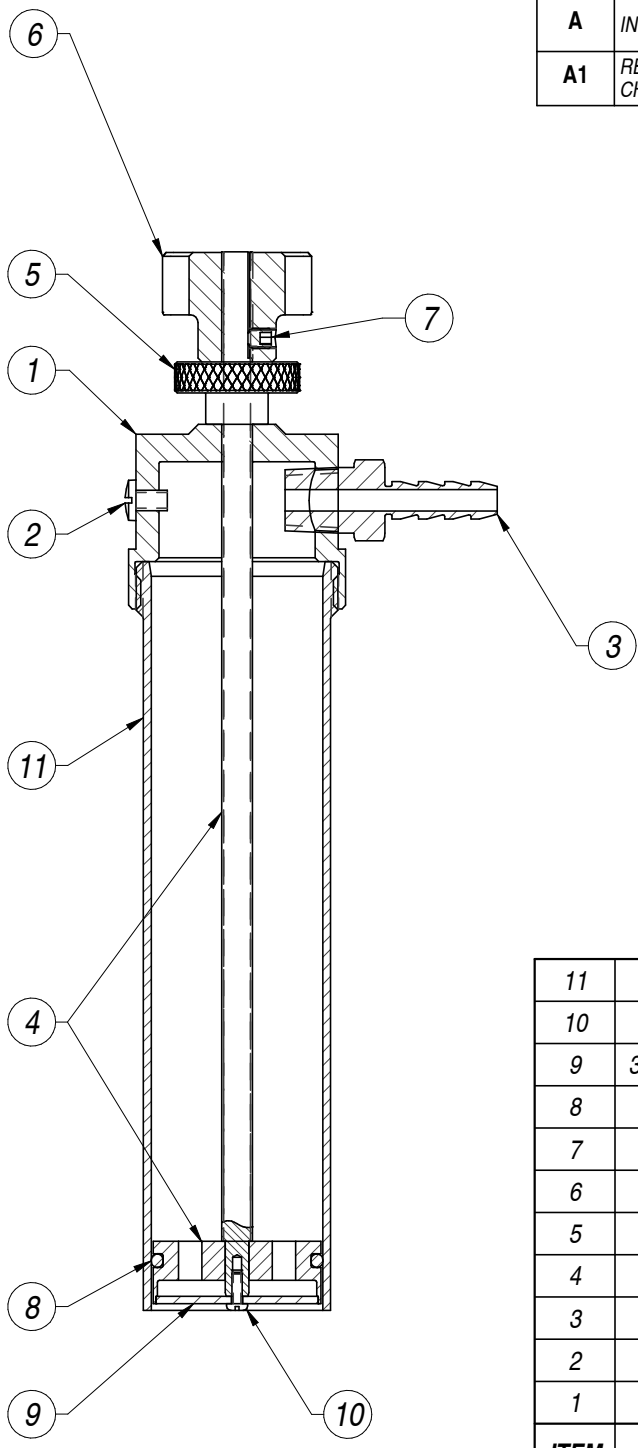

C

C

B

B

A

A

| 11 | 3008-GC-0014 | GUN BARREL, Ø1.38" I.D. x 6.0" LG. | 1 | EA. |
|------|-----------------|---------------------------------------|------|------|
| 10 | 0030-2A-0029 | PAN HD. M.S., 2-56UNF x 3/8", SLOTTED | 1 | EA. |
| 9 | 3008-SE-1013-20 | FILTER, Ø1.37" x 20µM, 316 S.S. | 1 | EA. |
| 8 | 0016-2A-5058 | O-RING, -122, SILICONE, 70 DURO | 1 | EA. |
| 7 | 0035-2A-0004 | SOCKET SET SCREW, 8-32 x 3/16" S.S. | 1 | EA. |
| 6 | 0018-SE-0006 | KNOB, 4-PRONG, Ø1-1/2" | 1 | EA. |
| 5 | 0018-2A-0004 | THUMBNUIT KNURLED | 1 | EA. |
| 4 | 3008-SE-1012 | PISTON/STEM ASS'Y | 1 | EA. |
| 3 | 2007-2A-0015 | MALE HOSE BARB, 1/4" NPT x 1/4" BARB | 1 | EA. |
| 2 | 0030-2A-0005 | BIND HEAD M.S. 8-32 X 1/4" L.G. | 1 | EA. |
| 1 | 3008-SE-0056 | CAP, Ø1-3/8in. I.D. x Ø1-1/2 in. O.D. | 1 | EA. |
| ITEM | PART NO. | DESCRIPTION | QTY. | UOM. |

KINEMATICS & CONTROLS CORPORATION
www.kcontrols.com

⊕ NOTICE!
This drawing, including all information contained hereon, is the exclusive proprietary property of Kinematics & Controls Corporation. It is disclosed with the understanding it will be retained in confidence, and will neither be duplicated nor copied in whole or in part, nor used for any purpose other than that for which disclosed. This drawing is to be returned upon request.

| | | | |
|--|--|----------------------|---|
| TOLERANCES (EXCEPT AS NOTED) | TITLE: FILLING GUN, Ø1-3/8" I.D. x 6" LG. (S.S. FILT.) | | |
| .XXX±.005 .XX±.010 FRACT. ±1/64 ANGLE ±1/2° | MATERIAL SEE TABLE | | FINAL ASS'Y 3008-0011 |
| DRAWN: JJR | SCALE: NONE | FINISH N/A | REQ'D. NEXT ASS'Y 1 3008-0011 |
| DATE: 1/11/06 | DWG. NO. 3008-SE-1011 | | REV. A1 |

1

2

3

4