

REV.	DESCRIPTION	DATE BY
-	FIRSTRELEASE	6/2/07 JJR
-	ITEM 4, PAN H.D M.S., 2-56 x 3/8" L., WAS BUTTON HD. M.S., 2-56 x 1/4" L.; NOREV. LETTER CHANGE.	2/24/11 JJR

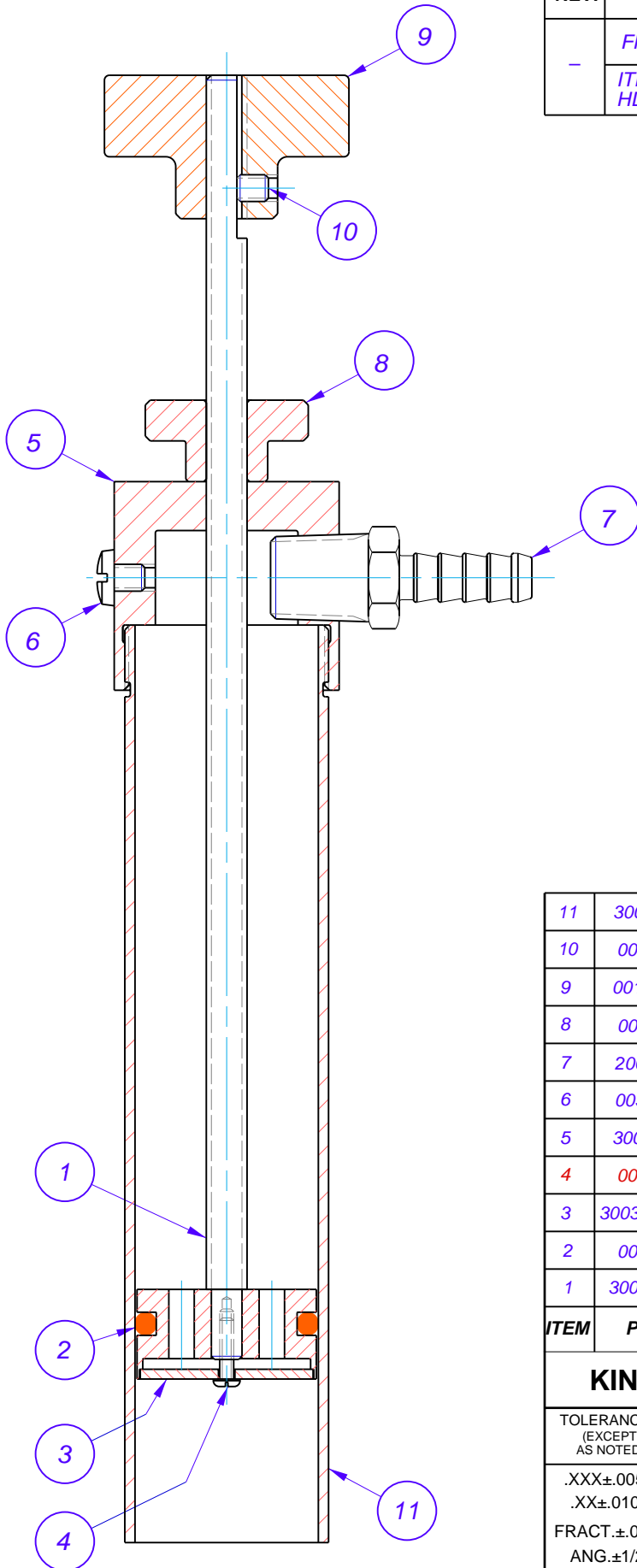

**NOTICE!**

This drawing, including all information contained hereon, is the exclusive proprietary property of Kinematics & Controls Corporation. It is disclosed with the understanding it will be retained in confidence, and will neither be duplicated or copied in whole or in part, nor used for any purpose other than that for which disclosed. This drawing is to be returned upon request.

11	3003-AC-0003	B	BARREL	1	EA.
10	0035-2A-0004	-	SET SCREW, 8-32 x3/16" (S.S.)	1	EA.
9	0018-GC-0006	A	KNOB, 4-PRONG	1	EA.
8	0018-2A-0004	-	LOCKNUT	1	EA.
7	2007-2A-0015	-	HOSE BARB FITTING, 1/4 x 1/4 (S.S.)	1	EA.
6	0030-2A-0005	-	BIND. HD. M.S. 8-32 X 1/4" (S.S.)	1	EA.
5	3003-GC-0006	A	CAP	1	EA.
4	0030-2A-0029	-	PAN HD. M.S. 2-56 X 3/8" L. (S.S.)	1	EA.
3	3003-GC-1009-20	-	FILTER, 316 S.S. 20 MICRON	1	EA.
2	0016-2A-5052	-	O-RING, -212 SILICONE	1	EA.
1	3003-GC-1002	-	PISTON/STEM ASS'Y	1	EA.
ITEM	PARTNO.	REV.	DESCRIPTION	QTY.	UOM.

**KINEMATICS & CONTROLS CORPORATION**

TOLERANCES (EXCEPT AS NOTED)	TITLE	FILLINGGUN ASS'Y, Ø1-1/8 I.D. (w/S.S. FILTER)		JOB NO.	3003
.XXX±.005 .XX±.010	MAT'L	SEE TABLE		FINAL ASS'Y	3003-1001
FRACT.±.015 ANG.±1/2°	FINISH	NONE	REQ'D	N/A	NEXT ASS'Y 3003-1001
DWN	JJR	DATE	6/2/07	SCALE	DWG. NO.
APP'D		DATE		NONE	3003-GC-1001
					REV.
					-