

Installation &
Operating Instructions

Series 5131
“Smart-Bloc® II, V.3.0”
Liquid Level Controllers

First Release August 1, 2012

INSTALLATION & OPERATING INSTRUCTIONS
Series 5131, Smart-Bloc® II Ver. 3.0, Liquid Level Controllers (First Release)

TABLE OF CONTENTS

INTRODUCTION	3
SPECIFICATIONS	4
FEATURES	4
Pushbutton Calibrate	4
User Selectable Modes	4
Ambient Light Immunity	4
Continuous Fault Monitoring	4
L.E.D. Indicator	4
D.I.N. Rail Mounting	4
USER SELECTABLE OPTIONS	5
Modes of Operation	5
• INDEPENDENT MODES	5
• DUAL MODES	5
Pump “UP” Mode	6
Pump “DOWN” Mode	7
• SENSOR DISABLE	7
INSTALLATION & SETUP PROCEDURES	8
TABLES	10
Summery of User Programmable Functions.....	10
Table I. Programmable Functions Table.....	10
SENSOR STYLES	11-13
SENSOR CONNECTIONS	14-19
OUTPUT CONNECTIONS	20
Power Outputs.....	20
Fault Output.....	20
TERMINAL CONFIGURATIONS	21
SUPPORT	22
WARRANTY	22
IMPORTANT NOTICE TO PURCHASER	22

INSTALLATION & OPERATING INSTRUCTIONS

Series 5131, Smart-Bloc® II Ver. 3.0, Liquid Level Controllers (First Release)

INTRODUCTION

Kinematics' Series 5131, Smart Bloc® II, V.3.0 liquid level controllers, are low-power, dual-point amplifier/controllers designed for use with any of Kinematics' "BASIC" output, point-type liquid level sensors. These controllers are microprocessor based and D.I.N. rail mountable.

This manual outlines the operating features and details the installation procedures for the following model numbers.

P/N **5131-0003** Smart-Bloc® II, V.3.0 110-120V-50/60 Hz.
P/N **5131-0007** Smart-Bloc® II, V.3.0 220-230V-50/60 Hz.
P/N **5131-0025** Smart-Bloc® II, V.3.0 9-28 VDC.

All models listed above are designed to:

1. Accept the designated voltage input.
2. Provide pulse-modulated, D.C. power to one (1) or two (2) Kinematics' single point optoelectronic liquid level sensors, or to a single, Kinematics' dual-point optoelectronic liquid level sensor.
3. Receive back the sensors' output signals as microprocessor inputs.
4. Provide "dry" contact **power** output(s) to the "outside world" in accordance with the selected mode of operation.
5. Provide a "dry" contact **signal** output to the "outside world" whenever a functional sensor or sensors fail to function properly or "die" completely.

INSTALLATION & OPERATING INSTRUCTIONS

Series 5131, Smart-Bloc® II Ver. 3.0, Liquid Level Controllers (First Release)

SPECIFICATIONS

Microprocessor	Texas Instruments, LM3S811
Package Size	1.16"W. X 3.12"D. X 2.72"H.
Mounting	D.I.N Rail or Flush Mounting.
Input Voltage	Standard, 115 Volt, 50/60 Hz. Optional, 230 Volt, 50/60 Hz. Optional, 8-28 Volts D.C.
Power Output	Dry Contacts (1 Form A), 8 Amp. @ 250 V.A.C., 30 V.D.C.
Fault Out.....	Dry Contacts (1 Form A), 1.0 Amp.
Power Consumption	1/8 W. (Avg.), 1/4 W. (Max.)
Operating Temperature Range	(-) 20°C To (+) 80°C.

FEATURES

- **Pushbutton Calibrate.** One-touch, automatic calibration of the sensor's switching-point. Microprocessor algorithm sets the switch point to the most appropriate setting to help overcome the effects of droplets or condensation clinging to the sensor tip and giving false "WET" signals.
- **User Selectable Modes.** The user selectable options include selection of operating "Mode", i.e., "***Independent***" action or "***Dual***" action (Pump "up"/ Pump "down"); Sensor normally "Wet" or normally "Dry"; Time Delay on "Make" only; Time Delay on "Break" only; Time Delay on both "Make" and "Break"; No Time Delay; Sensor disable and "Calibrate".
- **Ambient Light Immunity.** All Smart-Bloc® II, V.3.0 models provide a multiplexed, pulse-modulated input to each sensor, and a filtered receiver/amplifier circuit for virtual immunity to false-triggering by incident ambient light.
- **Continuous Fault Monitoring.** An embedded fault monitoring algorithm designed to work in conjunction with patented sensor hardware continuously monitors the condition of each sensor, and reports any faulty or non-functional sensor immediately upon its detection.
- **L.E.D. Indicator.** Face mounted L.E.D. provides visual indication of the status of the relay. In the ***Independent*** mode of operation, the LED is illuminated when the relay for that channel's is energized. In the ***Dual*** mode, an illuminated LED indicates that the sensor associated with that particular channel is WET.
- **D.I.N. Rail Mounting.** All Smart-Bloc® II, V.3.0 models mount on any one of three universal D.I.N. rail styles.

INSTALLATION & OPERATING INSTRUCTIONS
Series 5131, Smart-Bloc® II Ver. 3.0, Liquid Level Controllers (First Release)

USER SELECTABLE OPTIONS

All Smart-Bloc® II V.3.0 models are user programmable by selecting an appropriate position on a rotary DIP switch. The switch actuator is accessible through the center hole in the front face of each panel. Eight (8) ***Independent*** modes of operation are provided. Additionally, two ***Dual*** modes of operation, i.e. "Pump-Up" and "Pump-Down" are also provided. One position of the Hex switch is designated for the pushbutton calibration. Another disables the sensor connected to that channel.

• **Modes of Operation.**

1. INDEPENDENT MODES All Smart-Bloc® II V.3.0, liquid level controllers amplify the output signals of and provide independent real-world output for either one (1) or two (2) optoelectronic liquid level sensors operating in any one of the eight (8) modes listed below. When using Smart-Bloc® II, V.3.0 with two sensors in any of the "***Independent***" modes, both sensors may be in a single tank, or they may be installed in separate tanks.

HEX

FUNCTION

0	Normally "Wet" (Energize when dry), 0 Sec. Delay "Make", 0 Sec. Delay "Break"
1	Normally "Wet" (Energize when dry), 0 Sec. Delay "Make", 5 Sec. Delay "Break"
2	Normally "Wet" (Energize when dry), 5 Sec. Delay "Make", 0 Sec. Delay "Break".
3	Normally "Wet" (Energize when dry), 5 Sec. Delay "Make", 5 Sec. Delay "Break".
4	Normally "Dry" (Energize when wet), 0 Sec. Delay "Make", 0 Sec. Delay "Break".
5	Normally "Dry" (Energize when wet), 0 Sec. Delay "Make", 5 Sec. Delay "Break".
6	Normally "Dry" (Energize when wet), 5 Sec. Delay "Make", 0 Sec. Delay "Break".
7	Normally "Dry" (Energize when wet), 5 Sec. Delay "Make", 5 Sec. Delay "Break".

In any of the ***Independent*** modes, the "Fault" relay contacts will close when either sensor experiences a failure or a fault.

2. DUAL MODES Although Smart-Bloc® II, V.3.0 controllers will support a single sensor or sensors working independently on either or both channels, their elegance lies in their ability to process the two sensor inputs, and to provide a single output signal based on their combined states. Two "***Dual***" modes are provided for this purpose. These two additional modes, "Pump-Up" (Hex "D") and "Pump-Down" (Hex "E"), are described below.

INSTALLATION & OPERATING INSTRUCTIONS

Series 5131, Smart-Bloc® II Ver. 3.0, Liquid Level Controllers (First Release)

Pump-Up Mode. The Pump-Up control mode is chosen when it is desired to maintain a constant level between two points in a process tank, and the process is normally depleting liquid from the tank. In this mode, the controller's output relay contacts are closed only when both sensors are dry, and are open only when both are wet. The schematic below best describes this mode.

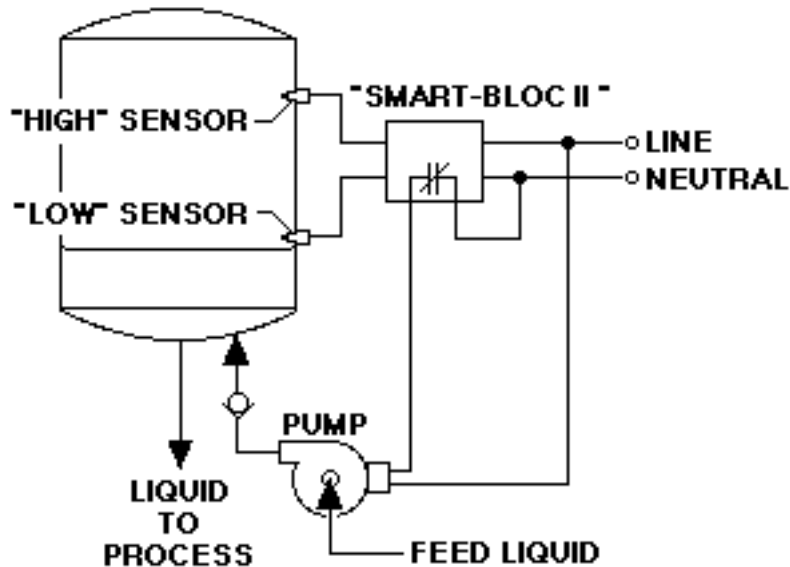

On power-up, both of the sensors are dry. Consequently, the controller's output relay contacts close to start a pump or open a "fill" valve. The liquid flows into the tank until its level rises to a point above the upper sensor. Now both sensors are wet, and the relay contacts open, stopping the pump. When the process causes the liquid level to fall below the lower sensor, both sensors again become dry, and the filling action restarts to restore the liquid to its higher level.

INSTALLATION & OPERATING INSTRUCTIONS

Series 5131, Smart-Bloc® II Ver. 3.0, Liquid Level Controllers (First Release)

Pump-Down Mode. The Pump-Down control mode is chosen when it is desired to maintain a constant level between two points in a process tank, and the process is normally adding liquid to the tank. In this mode, the controller's output relay contacts are closed only when both sensors are wet, and are open only when both are dry. The

The schematic below best describes its operation.

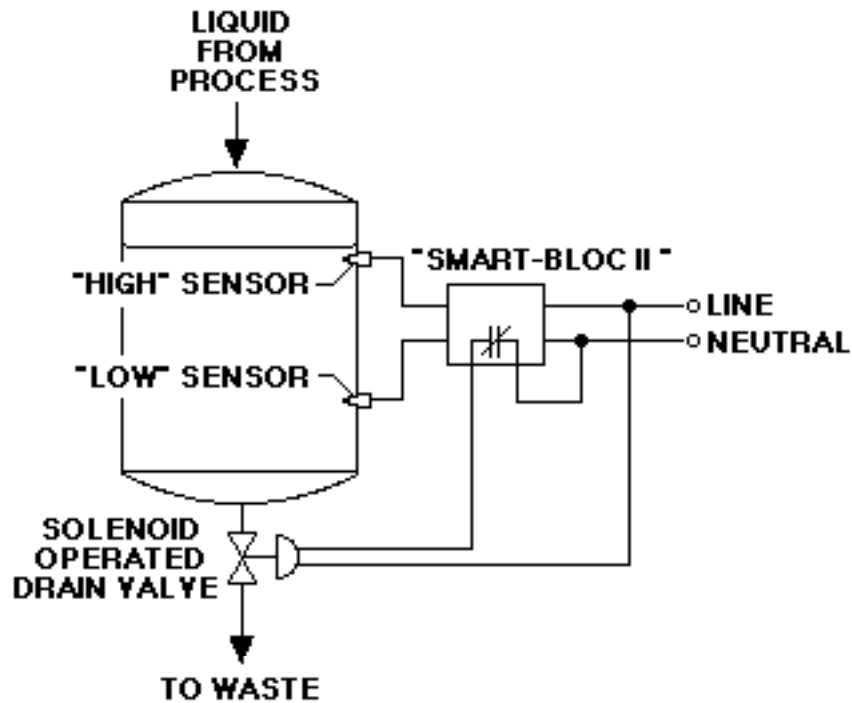

On power-up, the tank is empty and both sensors are dry. Therefore, the output relay contacts are open and no action occurs. As the process fills the tank, its liquid level rises to a point where eventually both sensors are wet. The relay contacts now close, and a "waste" pump starts or a "drain" valve is held open until the level in the tank drops to a point below the lower sensor. When the level reaches the point where both sensors are again dry, the relay contacts open and the draining action stops. When the process again causes the level to rise above the upper sensor, and both sensors are again wet, the draining action resumes to drop the liquid to a point below its lower level.

- **Sensor Disable.** The user may totally enable or disable any or both of the two sensor channels by setting the module's rotary dipswitch to Hex position "F". This is useful in temporarily silencing alarms from faulty sensors, or in preventing such alarms in cases where one of the channels is not being utilized. Whenever a channel is not being used, it should be disabled to prevent a constant "FAULT" condition from being reported.

INSTALLATION & OPERATING INSTRUCTIONS
Series 5131, Smart-Bloc® II Ver. 3.0, Liquid Level Controllers (First Release)

INSTALLATION & SETUP PROCEDURE

Refer to the diagrams and tables referenced in each paragraph below, and follow these simple steps for quick and easy installation.

1. **Fasten the “Smart-Blocs” in Place.** Smart-Bloc® II, V.3.0 models are D.I.N. rail mountable. Each unit is shipped with a small segment of perforated 35mm. D.I.N. rail to allow flush mounting in systems which do not utilize a D.I.N. rail mounting system. Remove and discard this small segment of D.I.N. rail for direct mounting into panels which already have a D.I.N. rail system installed.

2. **Connect the Sensors** Connect each sensor lead to its appropriate terminal position on the Smart-Bloc®. Note that sometimes all of the terminal block positions are not utilized. Refer to the sensor outline drawings and connection diagrams on pages ??? of this manual, or to the label on the side of the Smart-Bloc®, for the correct wiring scheme for the particular sensor and Smart-Bloc® purchased.

Caution! Double check that all sensor connections have been made correctly before applying power to any Smart-Bloc® II Controller. Improper connection will damage or destroy the sensors. Never connect or disconnect sensors while there is power applied to the controller.

3. **Connect the outputs.** Connect each of the relay outputs to its respective output device or P.L.C. Refer to the output connection diagrams on pages ___ of these instructions, or to the label on the side of the Smart-Bloc®, for the correct output wiring scheme.

4. **Connect power.** First, double check the voltage rating of the model you are installing. Next, connect the controller to an appropriate power supply. Refer to the tables on page ___ of this manual, or to the side label on the device itself, for the proper power connection scheme for each particular model.

5. **Calibrate** Set the mode selection switch to ***Hex Position “A”***. With power still applied, immerse the sensor to be calibrated in the working fluid. Be careful not to allow the tip of the sensor to come in contact with, or anywhere in close proximity to, a reflecting wall or surface
Next, press the calibrate P.B. switch. LED will light to indicate that the sensor is calibrated.
If the L.E.D. is blinking, check to ensure that all sensor connections are properly made.

INSTALLATION & OPERATING INSTRUCTIONS

Series 5131, Smart-Bloc® II Ver. 3.0, Liquid Level Controllers (First Release)

6. **Program the Module.** Select the desired mode of operation by positioning the Hexadecimal rotary D.I.P. switch to the desired functional setting as outlined in User Selectable Options Table below. (Refer to the summary tables on pages____ Below.)

7. **Voila!** Your installation is now complete!

INSTALLATION & OPERATING INSTRUCTIONS

Series 5131, Smart-Bloc® II Ver. 3.0, Liquid Level Controllers (First Release)

Summary of User Programmable Functions, “Smart-Bloc® II, V.3.0” (Hexadecimal Rotary D.I.P. Switch Settings)

Smart-Bloc® II, V3.0 controllers have two sensor channels. When the face of the controller is viewed with the red L.E.D. at the bottom and the P.B. Calibrate switch at the top, Channel 1 is the left hand channel. Channel 2 is on the right hand side. When using Smart-Bloc® II, V.3.0 controllers with sensors which are to function independently, both Channel 1 and Channel 2 Hex switches are set to the mode of operation desired for the sensor on each particular channel.

“Dual” mode settings are made ***ONLY*** on Channel 1 for ***BOTH*** sensors. Selection of either of the “Dual” modes on Channel 1 will override any selection made on Channel 2, except for Hex “F”, “Sensor Disable”.

Disabling Channel 2 allows a sensor on Channel 1 to function in any of the “Independent” modes. Similarly, disabling a sensor on Channel 1 also allows a sensor on Channel 2 to function in any of the “Independent” modes. However, disabling Channel 2 with one of the “Dual” modes selected on Channel 1 will disable both sensors.

Table 1. Smart-Bloc® II, V.3.0 Programmable Functions Table

<u>Channel 1 (Left)</u>				<u>Channel 2 (Right)</u>			
<u>Hex</u>	<u>“Make” Relay</u>	<u><----Time Delay ----></u>		<u>Hex</u>	<u>“Make” Relay</u>	<u><----Time Delay ----></u>	
		<u>On “Make”</u>	<u>On “Break”</u>			<u>On “Make”</u>	<u>On “Break”</u>
“0”	Dry	0	0	“0”	Dry	0	0
“1”	Dry	0	5	“1”	Dry	0	5
“2”	Dry	5	0	“2”	Dry	5	0
“3”	Dry	5	5	“3”	Dry	5	5
“4”	Wet	0	0	“4”	Wet	0	0
“5”	Wet	0	5	“5”	Wet	0	5
“6”	Wet	5	0	“6”	Wet	5	0
“7”	Wet	5	5	“7”	Wet	5	5
“8”	Unused	Unused	Unused	“8”	Unused	Unused	Unused
“9”	Unused	Unused	Unused	“9”	Unused	Unused	Unused
“A”	<u><----- Calibrate -----></u>			“A”	<u><----- Calibrate -----></u>		
“B”	Unused	Unused	Unused	“B”	Unused	Unused	Unused
“C”	Unused	Unused	Unused	“C”	Unused	Unused	Unused
“D”	<u><----- Pump UP-----></u>			“D”	<u><----- Pump UP-----></u>		
“E”	<u><----- Pump DOWN -----></u>			“E”	<u><----- Pump DOWN -----></u>		
“F”	<u><-----Sensor Disabled -----></u>			“F”	<u><----- Sensor Disabled -----></u>		

INSTALLATION & OPERATING INSTRUCTIONS

Series 5131, Smart-Bloc® II Ver. 3.0, Liquid Level Controllers (First Release)

SENSOR STYLES

The following diagrams illustrate the various styles of Kinematics' optoelectronic liquid level sensors that will function with this version of Smart-Bloc® II controllers. The diagrams on pages____ the following section illustrate how these different sensors are connected to the module. Note that some sensor styles have alternate color schemes for the wiring.

STYLE "A" **SINGLE LEVEL SENSOR** **(3-WIRE)**

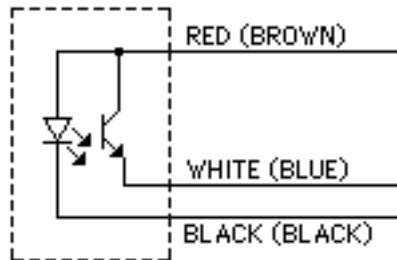

STYLE "B" **SINGLE LEVEL SENSOR** **(4-WIRE)**

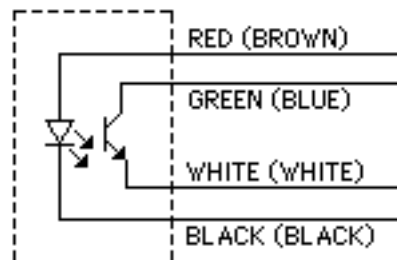

INSTALLATION & OPERATING INSTRUCTIONS
Series 5131, Smart-Bloc® II Ver. 3.0, Liquid Level Controllers (First Release)

STYLE "C"
DUAL LEVEL SENSOR
(5-WIRE, PARALLEL)

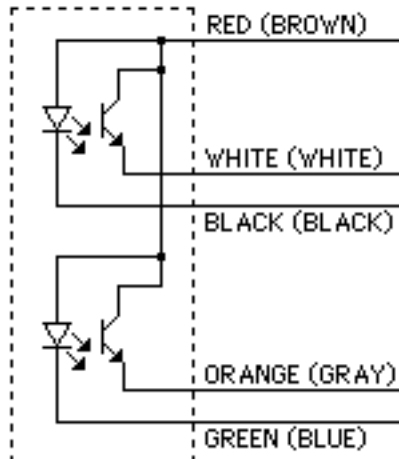

STYLE "D"
DUAL LEVEL SENSOR
(6-WIRE)

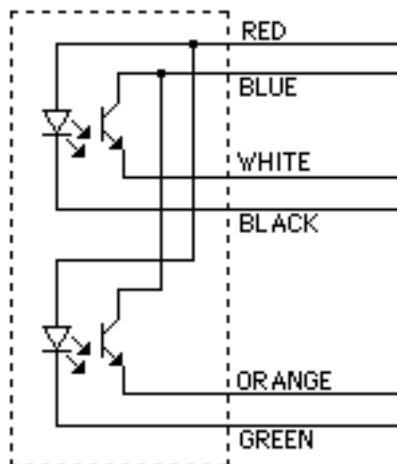

INSTALLATION & OPERATING INSTRUCTIONS
Series 5131, Smart-Bloc® II Ver. 3.0, Liquid Level Controllers (First Release)

STYLE "E"
DUAL LEVEL SENSOR
(5-WIRE, SERIES)

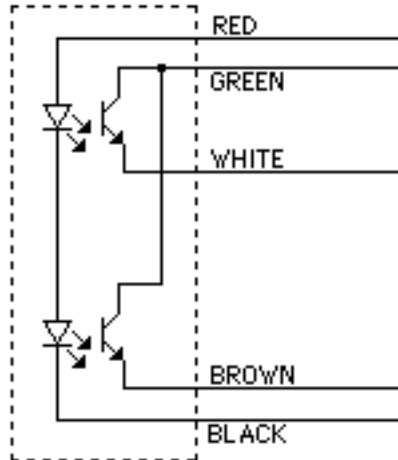

INSTALLATION & OPERATING INSTRUCTIONS

Series 5131, Smart-Bloc® II Ver. 3.0, Liquid Level Controllers (First Release)

SENSOR CONNECTIONS

Smart-Bloc® II controllers will accept and function with any of the single or dual point sensors (styles "A" through "E" shown above. Terminal positions 2, 3, 5, 6, 7, & 8 are used for sensor inputs to this controller. Refer to the general connection scheme below, and to the specific connection diagrams for each sensor type on the following pages. Always "Disable" any sensor channel not being utilized to avoid the possibility of any false signaling.

General Connection Scheme

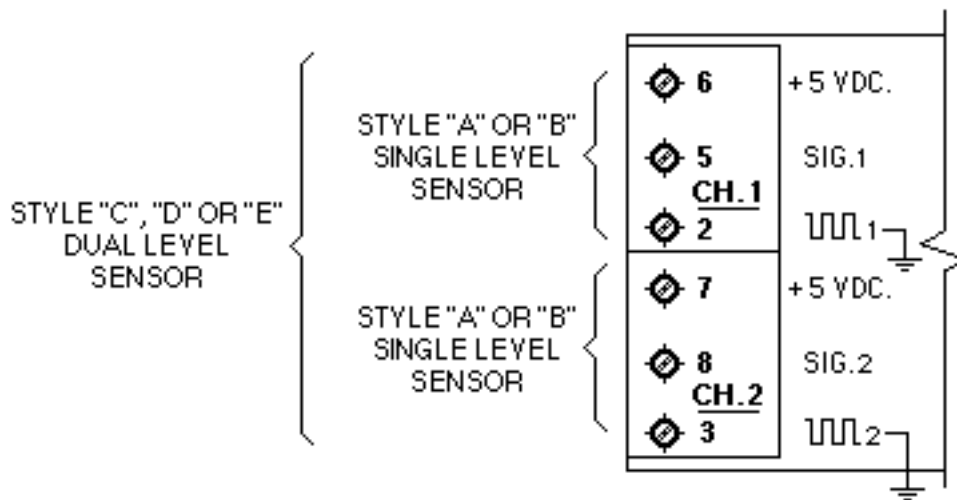

INSTALLATION & OPERATING INSTRUCTIONS
Series 5131, Smart-Bloc® II Ver. 3.0, Liquid Level Controllers (First Release)

Connecting Style "A" Sensors

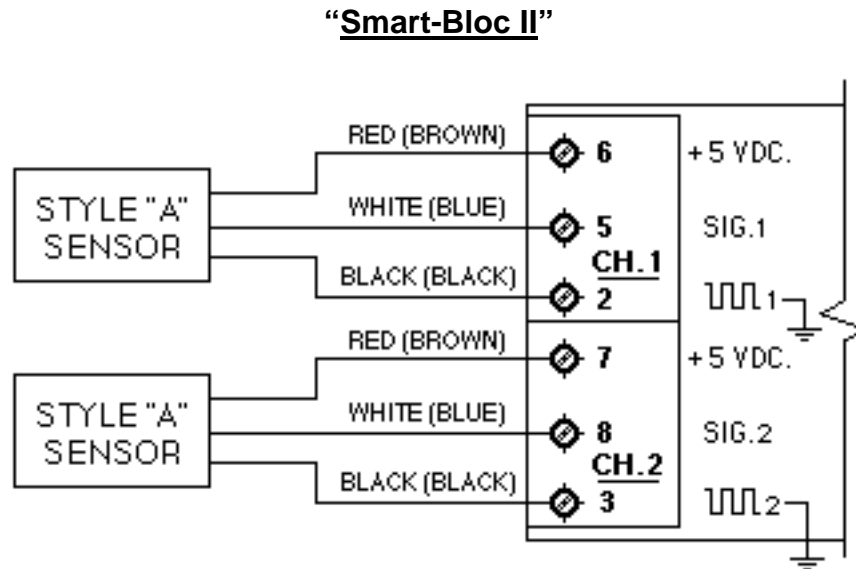

INSTALLATION & OPERATING INSTRUCTIONS
Series 5131, Smart-Bloc® II Ver. 3.0, Liquid Level Controllers (First Release)

Connecting Style “B” Sensors

“Smart-Bloc II”

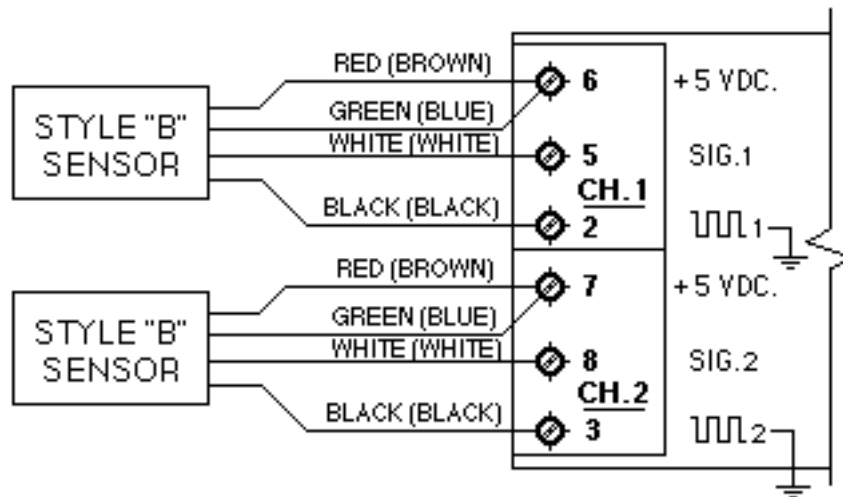

INSTALLATION & OPERATING INSTRUCTIONS
Series 5131, Smart-Bloc® II Ver. 3.0, Liquid Level Controllers (First Release)

Connecting Style “C” Sensors

“Smart-Bloc II”

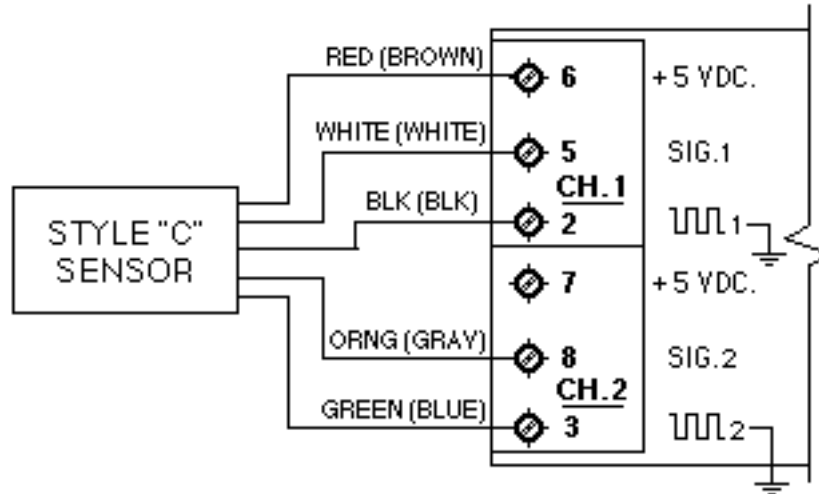

INSTALLATION & OPERATING INSTRUCTIONS
Series 5131, Smart-Bloc® II Ver. 3.0, Liquid Level Controllers (First Release)

Connecting Style “D” Sensors

“Smart-Bloc II”

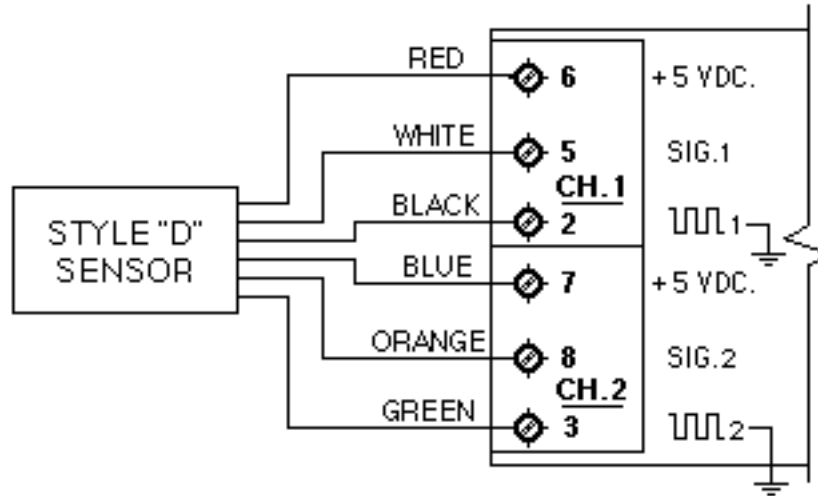

INSTALLATION & OPERATING INSTRUCTIONS
Series 5131, Smart-Bloc® II Ver. 3.0, Liquid Level Controllers (First Release)

Connecting Style “E” Sensors

“Smart-Bloc II”

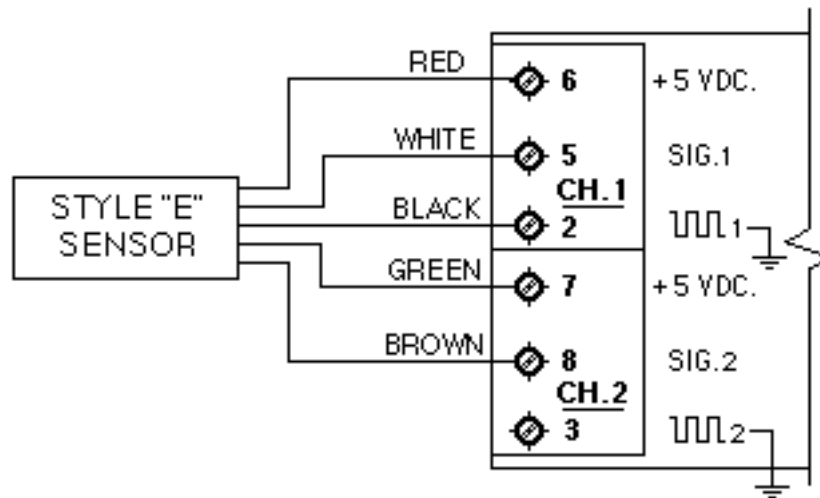

INSTALLATION & OPERATING INSTRUCTIONS
Series 5131, Smart-Bloc® II Ver. 3.0, Liquid Level Controllers (First Release)

OUTPUT CONNECTIONS.

Power Outputs.

Smart-Bloc® II, V.3.0 controllers have two (2) 1 Form A relay contact outputs. When operating the Smart-Bloc® II controllers in one of the “Independent” modes, the output relay contacts for channel 1 are across terminals 11 & 12. The output relay contacts for channel 2 are across terminals 9 & 10.

When operating “Smart-Bloc II”® controllers in one of the “Dual” modes, the two internal relays operate in parallel as a “2 Form A” relay.

Contact ratings for all “Smart-Bloc II” output relays are 8 Amps@ 250 V.A.C., 30V.D.C.

The status L.E.D.’s, on the front face of the Smart-Blocs, indicate the state of the relay contacts when the controller is operating in one of the Independent modes. In this mode, the status L.E.D.’s are “OFF” when their associated relay contacts are “OPEN”, and “ILLUMINATED” when they are “CLOSED”.

However, when the controller is operating in one of the “Dual” modes of operation, the L.E.D.’s serve only to indicate whether a particular sensor is “WET” or “DRY”. If a sensor is “WET”, it’s L.E.D. will be “ON”, If it is dry, its L.E.D. will be “OFF”. Therefore, in the “Pump-Up” mode (Hex “D”), both L.E.D.’s will be “OFF” when the output relay contacts are closed. And, consequently, both L.E.D.’s will be “ON” when the output relay contacts are closed when operating in the “Pump-Down” mode, (Hex “E”).

Fault Output

Smart-Bloc® II, V3.0 has a single 1 Form A, fault output relay whose contacts will close* whenever the microprocessor detects a “FAULT” condition at either one of the installed sensors. “Fault” relay contacts are rated at 1.0 amp. Outputs for fault signaling are located across terminal positions 13 & 14. Connect these points to an appropriate enunciator, a signal lamp or a P.L.C.

*(*As an option, fault relay contacts may be factory set to open on fault rather than closing on fault. Consult factory if you wish to have this alternate option.)*

INSTALLATION & OPERATING INSTRUCTIONS
Series 5131, Smart-Bloc® II Ver. 3.0, Liquid Level Controllers (First Release)

Terminal Configurations, “Smart-Bloc® II, V.3.0”

1. UNUSED
2. SENSOR #1, GROUND. (Pulsed)
3. SENSOR #2, GROUND. (Pulsed)
4. UNUSED
5. SIGNAL, SENSOR #1
6. SENSOR #1, V_{cc} (+5 VDC.)
7. SENSOR #2, V_{cc} (+5 VDC.)
8. SIGNAL, SENSOR #2
9. SIGNAL RELAY #2 CONTACT #1 (8.0 A.)
10. SIGNAL RELAY #2 CONTACT #2 (8.0 A.)
11. SIGNAL RELAY #1 CONTACT #1 (8.0 A.)
12. SIGNAL RELAY #1 CONTACT #2 (8.0 A.)
13. FAULT RELAY CONTACT #1 (1.0 A.)
14. FAULT RELAY CONTACT #2 (1.0 A.)
15. A.C. LINE <OR> (+V.D.C.)
16. A.C. NEUT. <OR> (D.C. Ground.)

INSTALLATION & OPERATING INSTRUCTIONS
Series 5131, Smart-Bloc® II Ver. 3.0, Liquid Level Controllers (First Release)

SUPPORT

Kinematics & Controls Corporation provides full technical support for its products. If you need assistance with any problem, please call us. Ask for technical support.

Toll-Free at 1-800-833-8103.

Outside of continental U.S.A., please call 1-352-796-0300

Or, email: techsupport@kcontrols.com

WARRANTY

All equipment described herein is warranted to the original purchaser for one year from the date of purchase to be free from defects in material and workmanship, but not against damages caused by misuse, negligence, accident or faulty installation. When the equipment is installed and operated in accordance with factory recommendations and instructions, Kinematics & Controls Corporation will repair or replace free of charge any part of the equipment found to be defective, upon prepaid return of the part to the factory during the warranty period. In no event shall any liability or obligation of

Kinematics arising from this warranty exceed the purchase price of the equipment.

All other warranties, whether expressed, implied or statutory such as warranties of merchantability or fitness for a particular purpose, are hereby excluded and disclaimed to the extent that they exceed the warranties expressly granted in this clause. In no event shall Kinematics be liable for consequential or incidental damages.

IMPORTANT NOTICE TO THE PURCHASER

All statements, technical information and recommendations are based on tests we believe to be reliable, but the absolute accuracy or completeness thereof is not guaranteed, and the following is made in lieu of all warranties expressed or implied. Seller's and manufacturer's only obligation shall be to replace such quality of the product proved to be defective. Neither seller nor manufacturer shall be liable for any injury, loss or damage, direct or consequential arising out of the use or the inability to use the product. Before using, user shall determine the suitability of the product for his intended use, and user assumes all risk and liability whatsoever in connection therein. No statement or recommendation shall have any force or effect unless in an agreement signed by officers of seller and manufacturer.