

HIGH-LEVEL ALARM

**Warns Against Potential Overfills/Spills of Liquid Chemicals or Waste.
Use In Any Drum Where Chemicals or Liquid Materials are Collected or Stored.**

- Operates With All Liquids, Both Conductive and Non-Conductive.
- Mounts in Standard 2" N.P.T. Bung Hole, Or Friction Fits Into Most Standard, Non-Threaded Drum Openings.
- Sounds a Shrill Audible Alarm, and Gives a Bright Visible Signal, Whenever the Level of an Accumulating Liquid Approaches the Top of it's Collection Vessel.

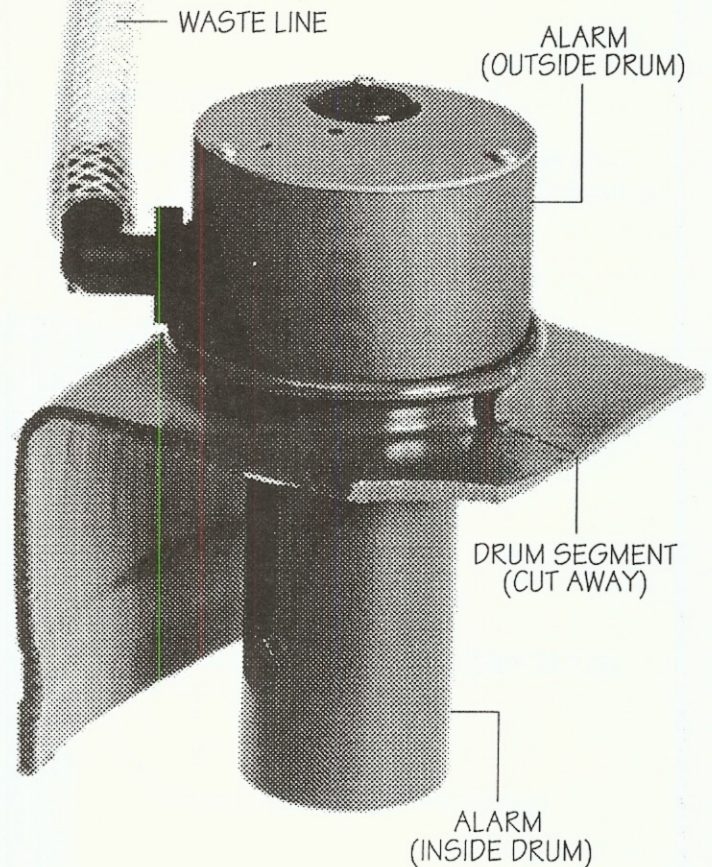

- Integral Barbed Fitting Accepts Any 1/2" I.D. Flexible Plastic or Rubber Waste Line From the Process.
- Operates on a Standard 9-Volt Alkaline Battery, Requires No Awkward Wiring.
- Built-In, Low-Battery Detection Circuit. Sounder "Chirps" When Battery Voltage Gets Too Low. Warns User When it's Time to Change Batteries.
- Low Power Consumption for Long Battery Life.
- Full One-Year Limited Warranty

ORDER DIRECTLY FROM FACTORY

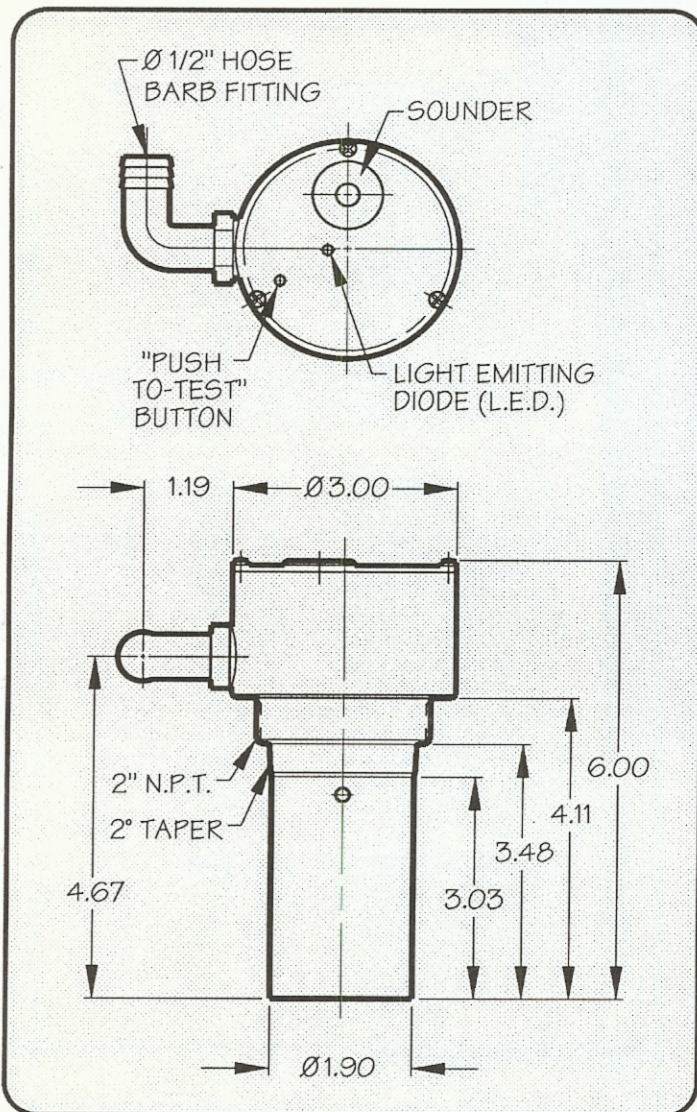

KINEMATICS & CONTROLS CORPORATION

14 BURT DRIVE • DEER PARK, NY 11729-5702 • Phone: 516-595-1803 • Fax: 516-595-1523

OR TOLL FREE: **800-833-8103** (Incl. NY State)

check these features...

EVERYTHING YOU EVER WANTED IN AN ANTI-OVERFLOW ALARM

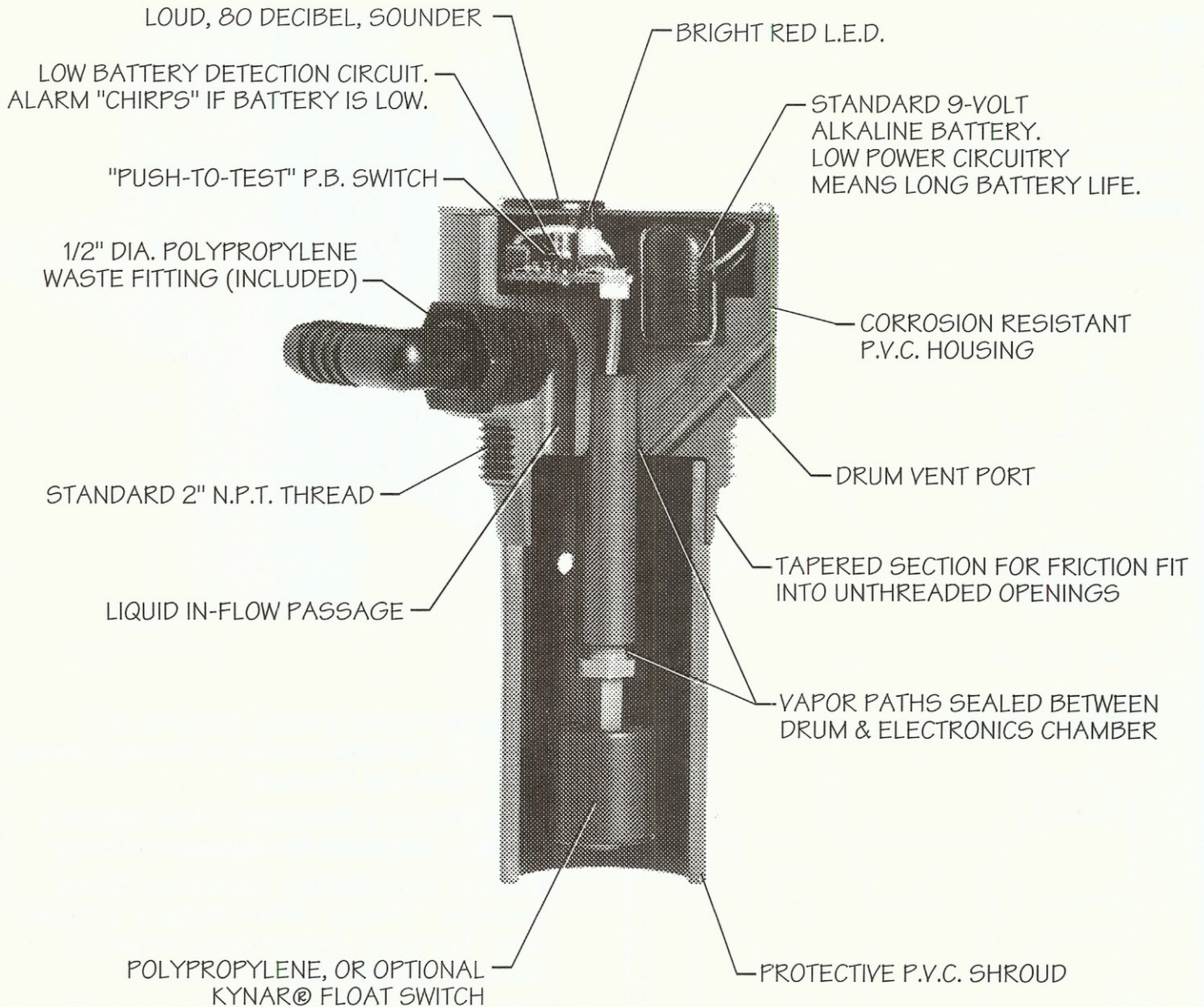

Kinematics' Model 5202 High-Level Alarm

KINEMATICS & CONTROLS CORPORATION

14 BURT DRIVE • DEER PARK, NY 11729-5702 • Phone: 516-595-1803 • Fax: 516-595-1523

OR TOLL FREE: **800-833-8103** (Incl. NY State)